

Week of April 6-10, 2020

Mrs. Grant - 4th Grade

Please pick 1 out of the 3 activities to do for the week. Please email me a picture of your child's work or activity or email me a description of the activities. Your child may also write a few sentences about the activity and submit via email or to the homework box that is located in the Lake Crest foyer. Your child should have also gotten an email for a google hangout set for Wednesday at 4pm. We've had about 6 kiddos each time so far, let's set a new record!!!

Please email me at jessica.grant@oakland5.org if you have questions! !

Class	Choice 1	Choice 2	Choice 3 (Enrichment)
Math	Adding Fractions Worksheet	Equivalent Fractions Strips worksheet	2 Rounds of Xtra math
Science	Light & Sound Worksheet	Read about these endangered animals from the Weekly Reader and write a 3 sentence summary about it. You do NOT have to create an account, just log in as a student and enter the password below. Pw: swingdrink494 https://superscience.scholastic.com/issues/2019-20/040120/comeback-creatures.html#900L	Make a homemade projector and take a picture of it. https://www.stevespanglerscience.com/lab/experiments/home-made-projector/
Language	Journal at least half of a page. You may have free choice on what you want to write about.	Write a letter to a friend or family member. Make sure to take a picture and email it to me or turn it into the homework box in the Lake Crest foyer.	Draw a plot diagram (mountain) and tell me the rising/falling action and the climax of a book you're reading.
Social Studies	Color in all of the different regions of the United States and label the map	Interview an adult by phone or in person that can recount a historical event in their lifetime. Have a conversation about what it was and why it happened. Email or turn in a summary of your conversation.	Read the story about Narwhal the Unicorn Puppy from the Google Classroom page and write a summary on it. Pw to scholastic is "swingdrink494"
Reading	Fill out the story element organizer with the book you're reading.	Read 2 chapters of a book and write a 3 sentence summary of it.	Video yourself reading a book and send it to me.



Adding fractions (like denominators)

Grade 4 Fractions Worksheet

Find the sum.

1. $\frac{7}{11} + \frac{2}{11} =$ _____

2. $\frac{3}{7} + \frac{2}{7} =$ _____

3. $\frac{2}{9} + \frac{3}{9} =$ _____

4. $\frac{2}{7} + \frac{6}{7} =$ _____

5. $\frac{19}{20} + \frac{19}{20} =$ _____

6. $\frac{24}{25} + \frac{20}{25} =$ _____

7. $\frac{1}{4} + \frac{1}{4} =$ _____

8. $\frac{5}{100} + \frac{9}{100} =$ _____

9. $\frac{5}{8} + \frac{7}{8} =$ _____

10. $\frac{11}{12} + \frac{11}{12} =$ _____

11. $\frac{2}{6} + \frac{5}{6} =$ _____

12. $\frac{1}{2} + \frac{1}{2} =$ _____

13. $\frac{2}{15} + \frac{3}{15} =$ _____

14. $\frac{4}{14} + \frac{6}{14} =$ _____

15. $\frac{11}{13} + \frac{12}{13} =$ _____

16. $\frac{3}{5} + \frac{4}{5} =$ _____

17. $\frac{7}{11} + \frac{5}{11} =$ _____

18. $\frac{1}{3} + \frac{1}{3} =$ _____

19. $\frac{2}{16} + \frac{13}{16} =$ _____

20. $\frac{8}{10} + \frac{5}{10} =$ _____

21. $\frac{6}{50} + \frac{15}{50} =$ _____

FRACTION STRIPS

Use these fractions strips to help you find the equivalent fractions.

Put the correct fraction into the box and fill in the answers below.



1)

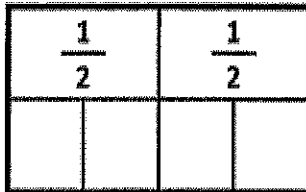

$$\frac{1}{2} = \frac{\quad}{4}$$

2)

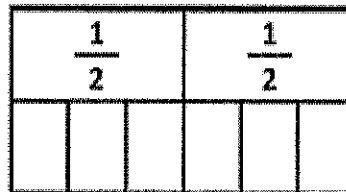

$$\frac{1}{2} = \frac{\quad}{6}$$

3)

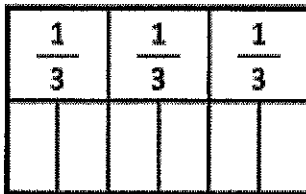

$$\frac{1}{3} = \frac{\quad}{6}$$

4)

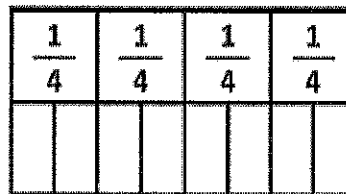

$$\frac{1}{4} = \frac{\quad}{8}$$

5)

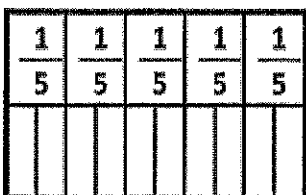

$$\frac{1}{5} = \frac{\quad}{10}$$

6)

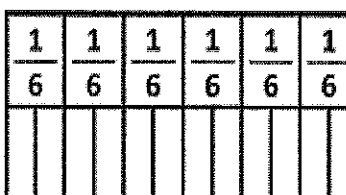

$$\frac{1}{6} = \frac{\quad}{12}$$

Now use the fraction walls to answer these questions.

7) $\frac{2}{2} = \frac{\quad}{4}$

8) $\frac{3}{4} = \frac{\quad}{8}$

9) $\frac{2}{3} = \frac{\quad}{6}$

10) $\frac{2}{5} = \frac{\quad}{10}$

11) $\frac{3}{3} = \frac{\quad}{6}$

12) $\frac{4}{6} = \frac{\quad}{12}$

13) $\frac{4}{5} = \frac{\quad}{10}$

14) $\frac{5}{6} = \frac{\quad}{12}$

LIGHT AND SOUND

1. Look at the pictures below and decide if it is a light or sound source. Place every letter in the right column of the table below.

a.



b.



h.



c.



f.



i.



d.



g.

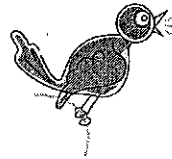

e.

Light source	Sound source

1. Light waves travel in a _____ line.

2. When light reflects, it bounces off the surface. Show the direction that you think it will reflect off a mirror on the pictures below.

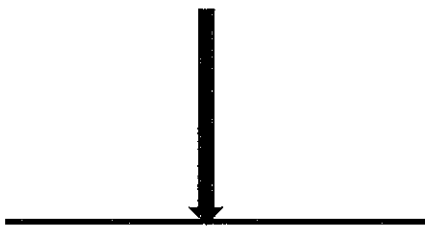

3. Thinking about what transparent, translucent and opaque means, write the correct word beside the picture that you think it shows.





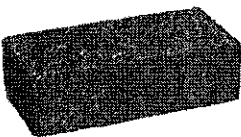

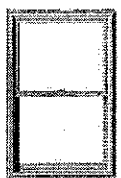

4. What happens when white light shines through a prism?

5. When you shine a white light through a red colored lens, what happens? Explain why this happens.

6. What causes sound? _____

7. What material does sound travel fastest through?

- a. air
- b. water
- c. solid (metal)

8. Explain how people can talk through paper cups that are attached by a string?

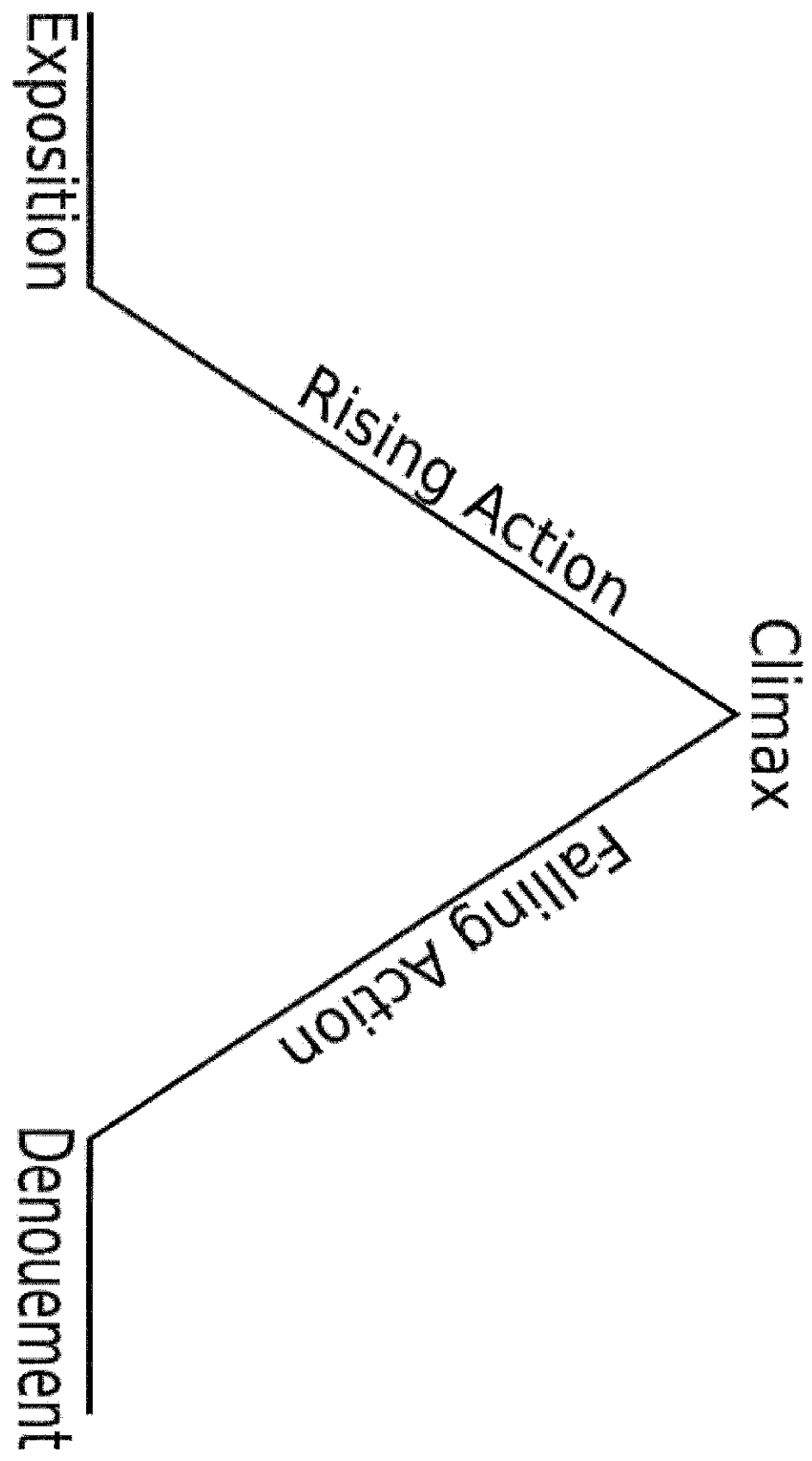



story **ELEMENTS** organizer

characters

Setting

Problem

Solution

Week of April 6-17, 2020

4th Grade Art

Mrs. Sweeney

Please pick 1 out of the 3 activities to complete every other week. Please email me a picture of your child completing the activities or submit the activity to the homework box located in the Lake Crest foyer. Some of the art projects require supplies. Please feel free to improvise if you do not have the required supplies, or reach out to me or the office and we will work together to get you what we need. Some basic supplies will be available for pick-up in the Lake Crest foyer.

Please email me at jill.sweeney@oakland5.org or call the school and leave a message, and I will give you a call as soon as I can. My office hours are 8-10 am on Mondays and Wednesdays and Tuesdays 10-12. I will be readily available at those times.

Class	Choice 1	Choice 2	Choice 3
4th Grade	Squirrel Monkey Drawing	Game Drawings	Landscape Perspective Drawing

Draw a Squirrel Monkey

L/Th/Art/Sweeney
April 6-17
Choice 1

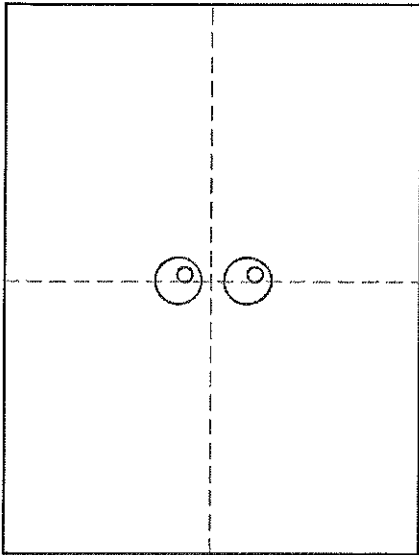

1. Make guidelines. Draw two circle eyes with dots inside.

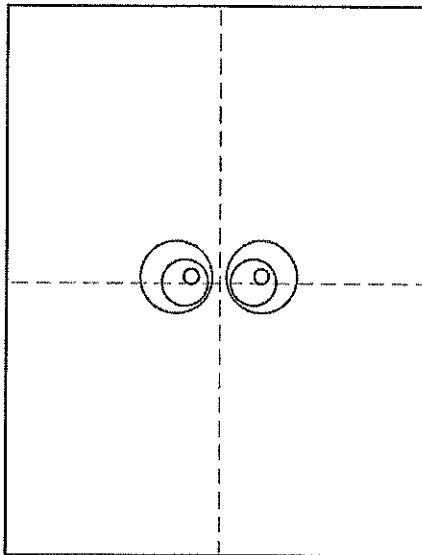

2. Draw rings around the eyes.

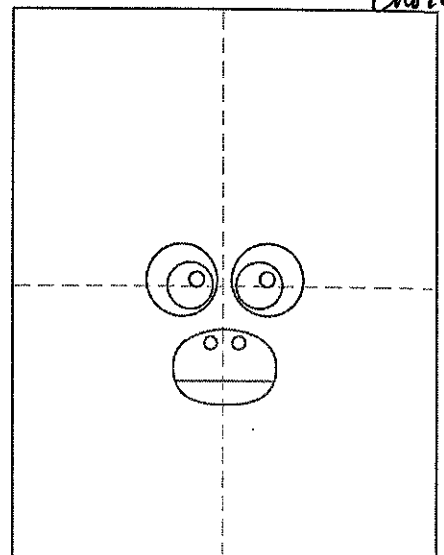

3. Add a mouth with a nose below.

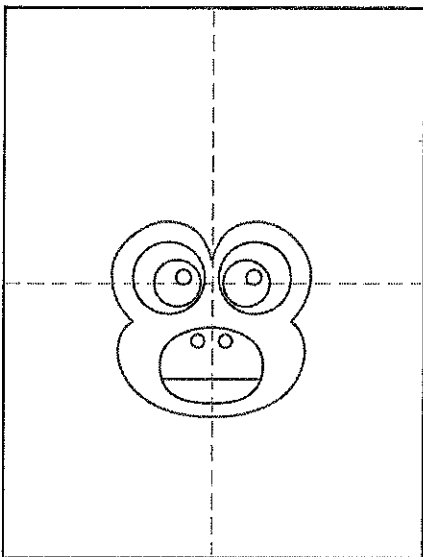

4. Draw the face shape around the eyes and mouth.

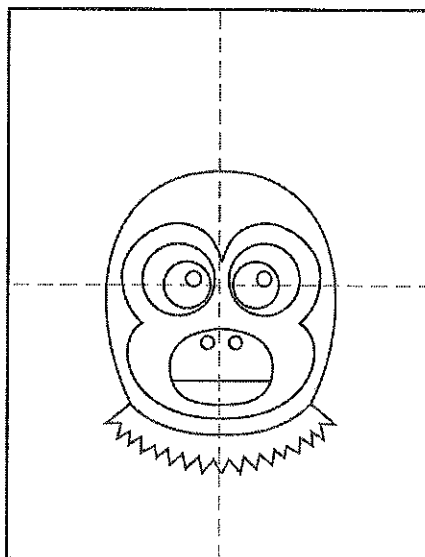

5. Add the head shape and neck fur.

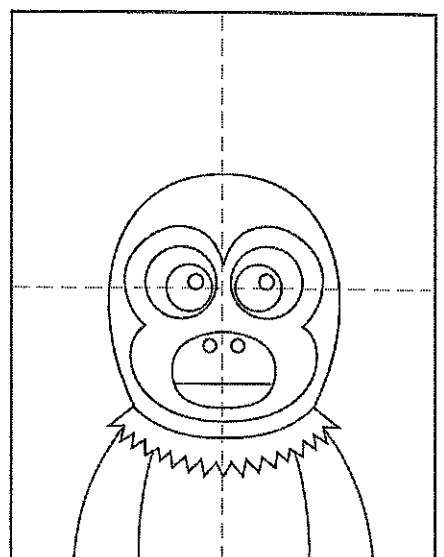

6. Draw a body below the neck fur.

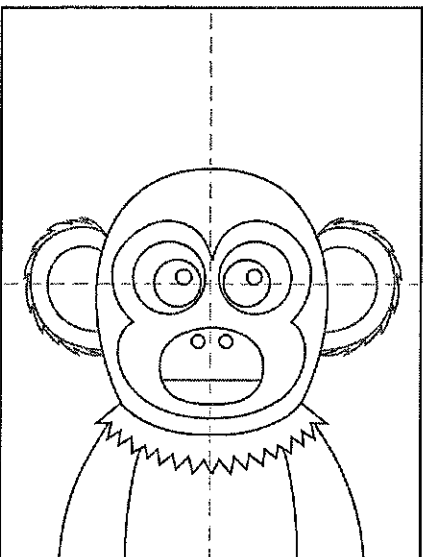

7. Add smooth ear lines. Draw fuzzy lines around the ears.

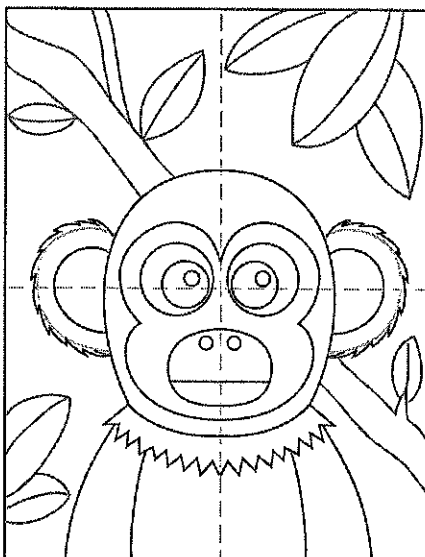

8. Erase the smooth ear line. Add lots of branches and leaves.

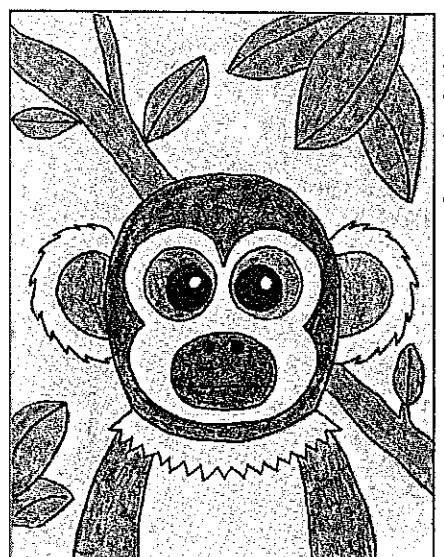

9. Trace with a marker and color.

A FUN GAME

see if you can draw....

- ① someone really tall,
- ② someone really small,
- ③ some one part machine,
- ④ someone part wild-thing
- ⑤ some one in a crazy hat,
- ⑥ someone with a Kitty cat,
- ⑦ someone who just goes and goes
- ⑧ someone with a great big nose.
- ⑨ some one who lives in the sea,
- ⑩ someone who looks just like me.

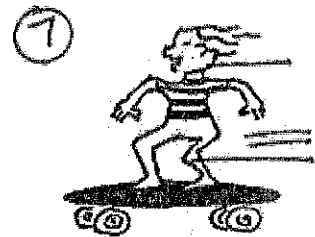
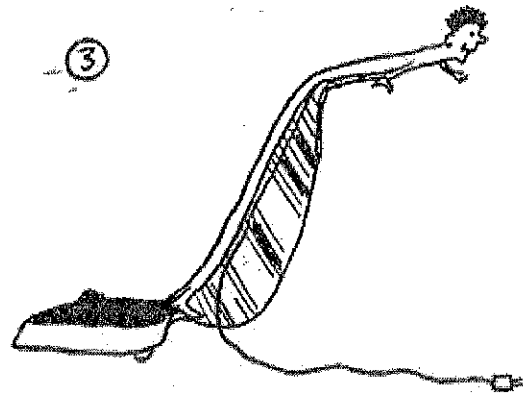
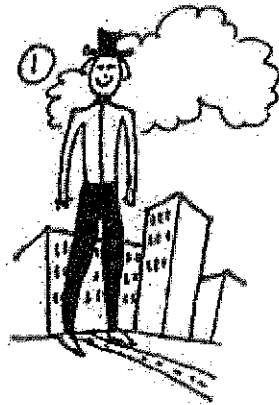

*Don't make your drawings anything like the examples above.

4th Grade/Art/Sweeney

April 6-17

Materials: Paper

Colored pencils or crayons

Landscape: Perspective/Value

Draw the 3 horizon lines showing the distance here, near, far.

Add trees as shown. Near large and lower on the page, near trunks start in middle of page and trees are shorter, far trunks start highest on page and are the shortest.

Add animals and/or buildings.

Color.



Winter Tree Landscape *Value Scale*

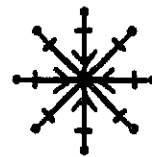
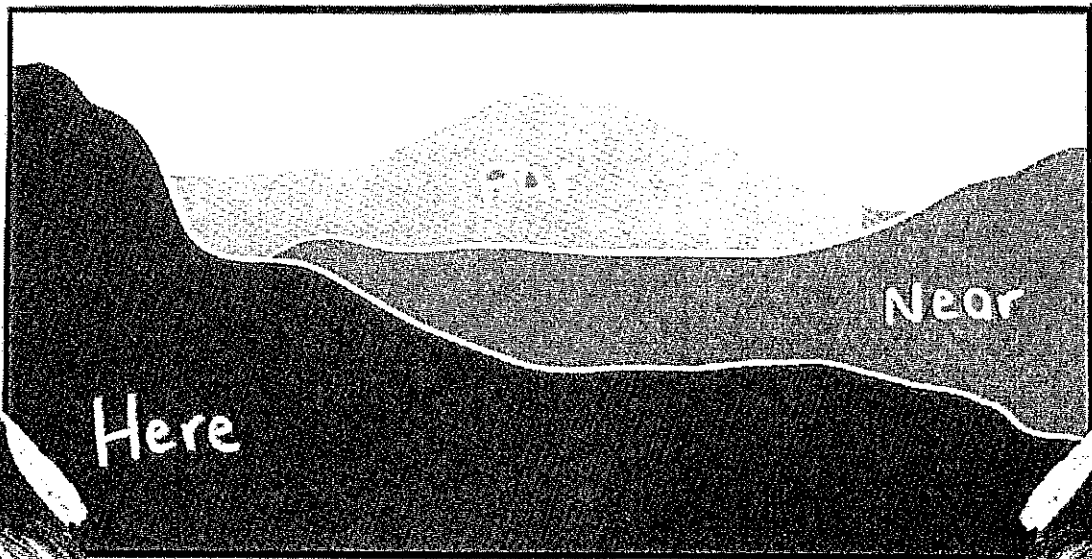

Weeks of April 6-17, 2020

April Lee

Hello, Parents! I miss making music with your young ones, but with these activity sheets come my warmest wishes, best virtual hugs, and hopes for a brighter tomorrow! With the holiday coming up and the warmer weather, I think we're well on our way!

Students will simply need a pencil and random found objects around your home to complete choice #1. For choice #2, students will need crayons, colored pencils, or markers.

Their work is due April 17th. Why two weeks? Because one week they should do Art and the other Music. But if they have work done they wish to return with their other school work on April 13, that's great!

My "office hours" are from 10:00 a.m. to noon on Mondays, Wednesdays, & Thursdays, but you can email me anytime with questions or concerns at april.lee@oakland5.org.

Class	Choice 1	Choice 2	Choice 3 (Enrichment)
4th Grade Music	Sound Scavenger Hunt	Easter Rhythms	Find a 4th grade activity on the Lake Crest Music group on Facebook and send Mrs. Lee a picture or a video.

Name _____

Grade _____

Sound Scavenger Hunt

Find objects that make the following types of sounds. Write the name of the object or describe how you made the sound on the lines next to the sound type.

You should have something different on each line.

1. Quiet _____

2. Loud _____

3. Long _____

4. Short _____

5. Fast _____

6. Slow _____

7. High-pitched _____

8. Low-pitched _____

9. Metallic _____

10. Woody _____

11. Other _____

How many sound types did you find? _____

2 = PURPLE	5 = BLUE
3 = YELLOW	6 = PINK
4 = GREEN	7 = ORANGE

$d = 1$ $d = 2$
 $\text{quarter note} = 1$ $\text{half note} = 2$
 $\text{eighth note} = 1$ $d. = 3$
 $\text{quarter note} = \frac{1}{2}$
 $\text{eighth note} = \frac{1}{2}$
 $d. = \frac{1}{2}$



Week of April 6-10, 2020

4th Grade PE

Mr. Anderson

Please pick 3 out of the 6 activities to do for the week, 3 activities per week. Please take a picture or a short video of your child performing the activity. Along with the video/picture, include the date as well when submitting to my email/phone. Your child may also write a few sentences about the activity if you don't have access or feel comfortable sharing electronically. I'm really excited to see what you are doing. Miss all of you, STAY SAFE.

My email is brian.anderson@oakland5.org, my phone number is 217-218-5420 or submit the written reflection to the homework box located in the Lake Crest foyer. My office hours are 10am-Noon. Feel free to email/call with any questions. Feel free to email/call anytime outside of those hours as well & I will get back with you as soon as possible.

Class	Choice 1	Choice 2	Choice 3	Choice 4	Choice 5	Choice 6 (Enrichment)
4 th PE	Take a Walk (at least 20 minutes)	Take a bike ride (at least 20 minutes)	DANCE PARTY!!! (play your favorite music, 5-6 songs, and dance like a goofball for at least 20 minutes)	50 Jumping Jacks 50 Push-ups (Knee push-ups if needed) 50 sit-ups • Chart your Time & send it back to me	15 minute Push-up challenge & 5 minute Body Squat challenge. (As many push-ups/body squats as you can get done in the allotted time. Chart your #'s/sets. Rest when needed.	Any other physical activity that you can think of around the house/garage. (BE CREATIVE) (20 min. at least) -yard work, basketball, creative ways to weight lift, run/sprint, etc. *YouTube is a great resource for finding activities w/ limited equipment.